

# ASSEMBLY INSTRUCTION

MODEL : LYRA



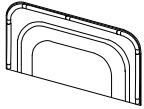
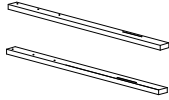

DESCRIPTION : LYRA -BEIGE-QB-HB W/LED & LYRA-BEIGE-KB-HB W/LED

Thank you for purchasing this quality product. Be sure to check all packing material carefully for small parts which may have loose inside the carton during shipment. Identify and count all parts and compare with the parts list below.

## PART LIST#

NO	NAME	PART	QTY
A	Headboard		1pc
B	Headboard Post - (L/R)		2pcs

## HARDWARE LIST#

NO	NAME	PART	QTY
1	Allen key 4mm		1pc
2	JCBC M6 x 35mm		6pcs
3	M6 Spring washer		6pcs
4	M6 Flat washer		6pcs
5	AC/DC Adapter		1pc

### HARDWARE LOCATED IN HEADBOARD BOX

Ensure the adapter socket is securely connected to the socket located behind the (A) Headboard.

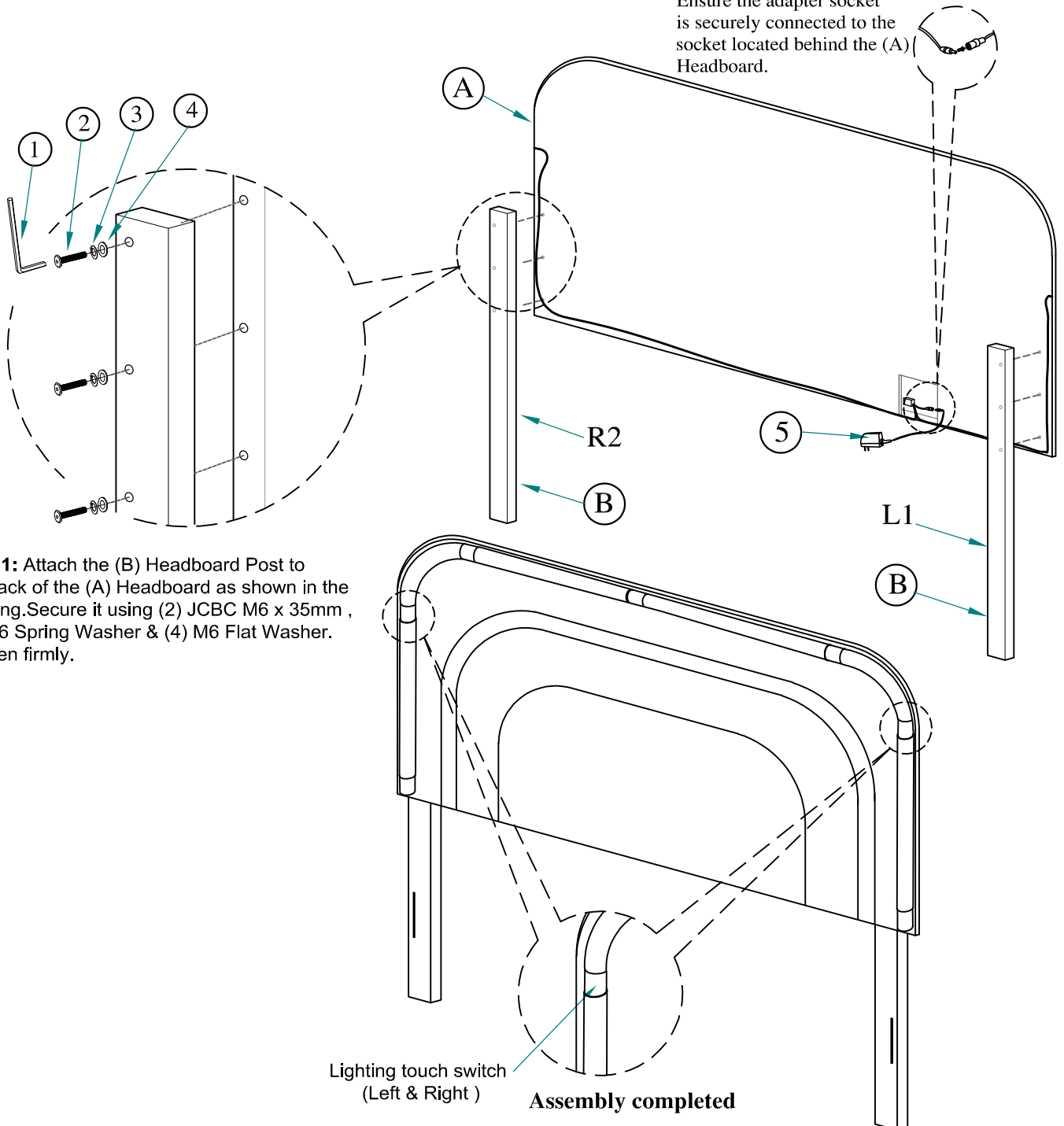

**Step 1:** Attach the (B) Headboard Post to the back of the (A) Headboard as shown in the drawing. Secure it using (2) JCBC M6 x 35mm , (3) M6 Spring Washer & (4) M6 Flat Washer. Tighten firmly.

Lighting touch switch  
(Left & Right)

Assembly completed



# ASSEMBLY INSTRUCTION

MODEL : LYRA



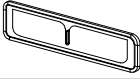
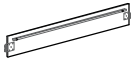
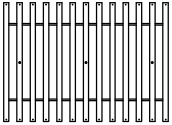
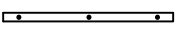

DESCRIPTION : LYRA-BEIGE-QB-HB W/LED & LYRA-BEIGE-QB-FB/SLATS & LYRA-BEIGE-QB/KB-SR  
LYRA-BEIGE-KB-HB W/LED & LYRA-BEIGE-KB-FB/SLATS & LYRA-BEIGE-QB/KB-SR



Thank you for purchasing this quality product. Be sure to check all packing material carefully for small parts which may have loose inside the carton during shipment. Identify and count all parts and compare with the parts list below.

## PART LIST#

NO	NAME	PART	QTY
A	Headboard		1pc
B	Footboard		1pc
C	Side Rail		2pcs
D	Roll Slat		13pcs
E	Center Vertical Slat		1pc
F	Slat Support Leg		3pcs
G	Acrylic Leg		2pcs

## HARDWARE LIST#

NO	NAME	PART	QTY
1	Allen key 4mm		1pc
2	JCBC M6 x 20mm		8pcs
3	M6 Spring Washer		8pcs
4	M6 Flat Washer		8pcs
<b>HARDWARE LOCATED IN ACRYLIC LEG BOX</b>			

5	Allen key 4mm		1pc
6	JCBC M6 x 60mm		3pcs
7	M6 Spring Washer		3pcs
8	Screw 32mm		26pcs
9	Adjustable Leveller		3pcs
<b>HARDWARE LOCATED IN FOOTBOARD BOX</b>			

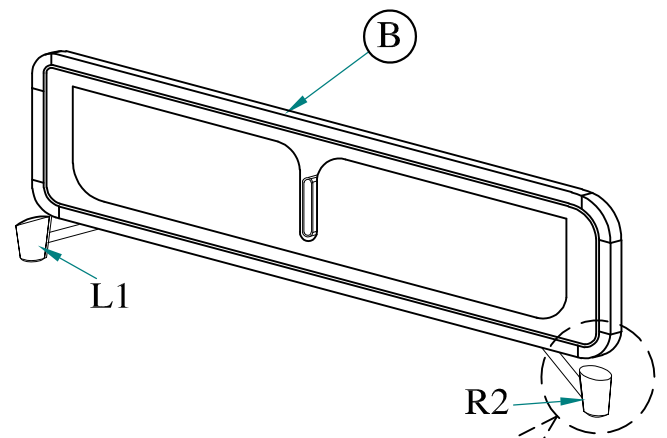
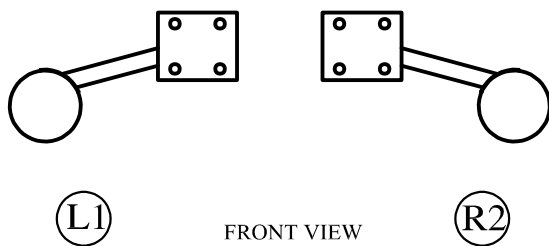

**Step 1 :** Secure the (G) Acrylic Leg to the bottom of (B) Footboard and tighten using (2) JCBC M6 x 20mm, (3) M6 Spring Washer & (4) M6 Flat Washer as diagram shown.

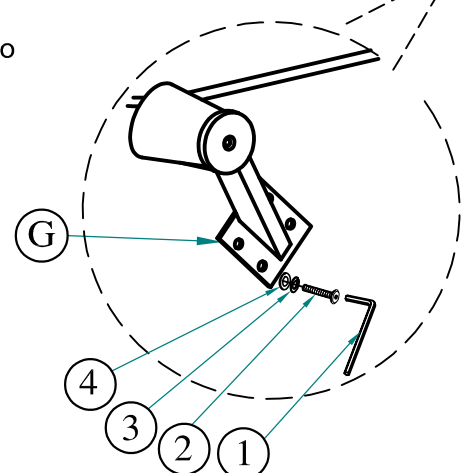
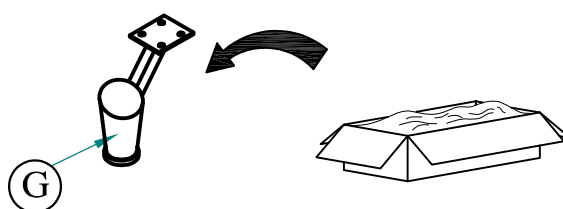

**Step 2 :**

Attach the (C) Side Rail to the (A) Headboard & (B) Footboard. Ensure the hooks are securely locked onto the pins.

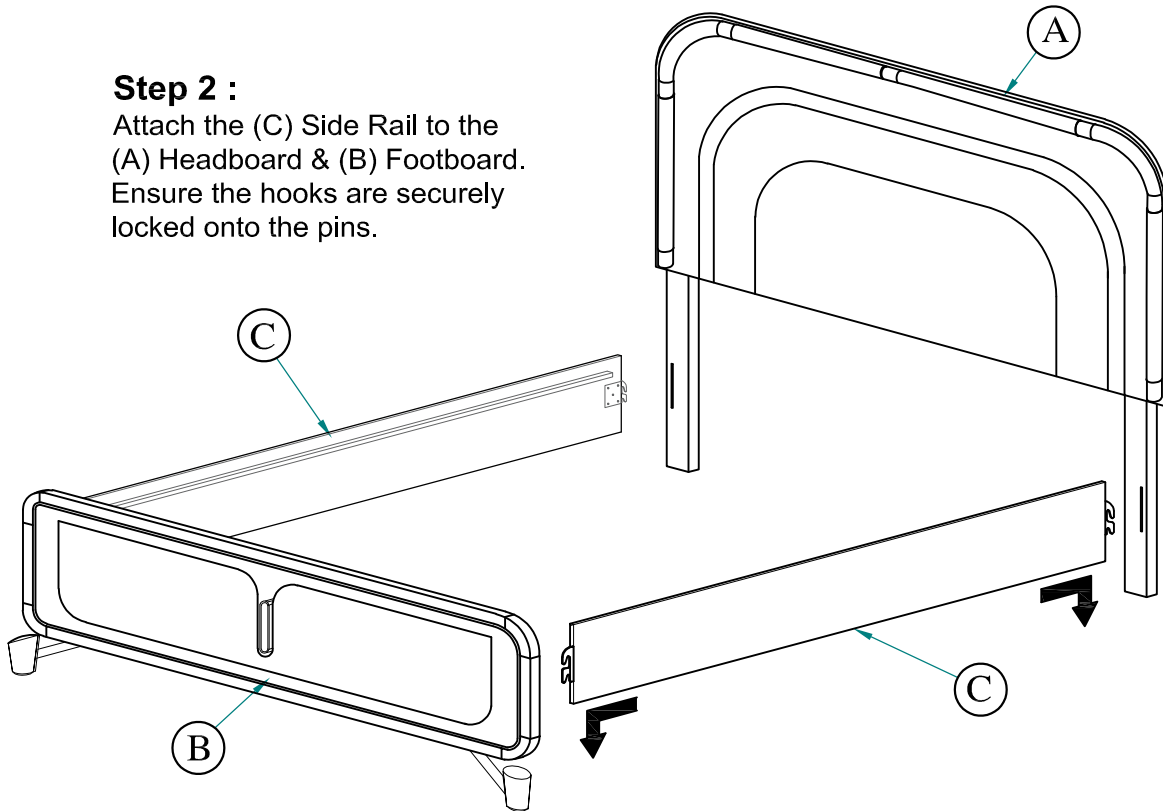

**Step 4 :**

Attach (F) Slat Support Leg & (E) Center Vertical Slat to the bottom of (D) Roll Slat using (6) JCBC M6 x 60mm & (7) M6 Spring Washer and tighten the JCBC with (5) Allen key. Adjust the (9) Adjustable Leveler to ensure the bed is level with the floor.

**Step 3 :**

Secure the (D) Roll Slat using the (8) Screw 32mm provided.

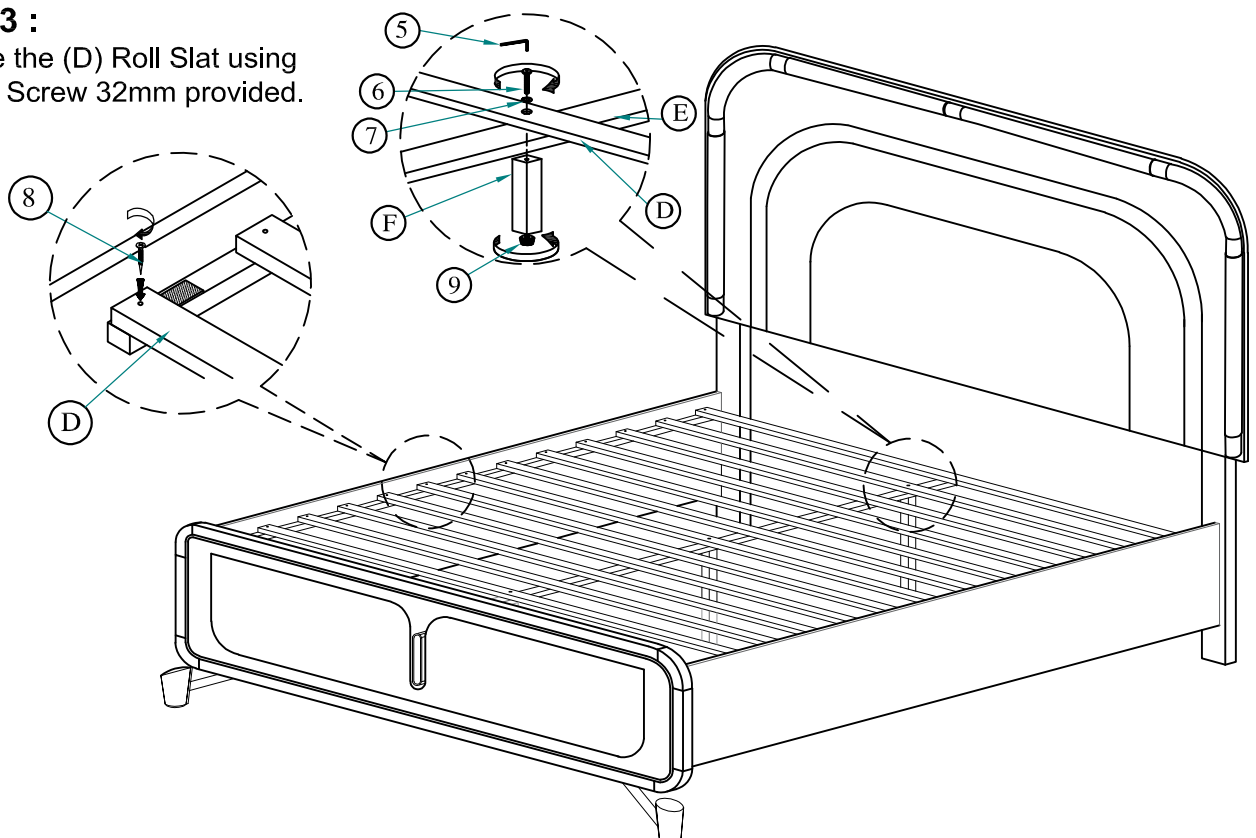

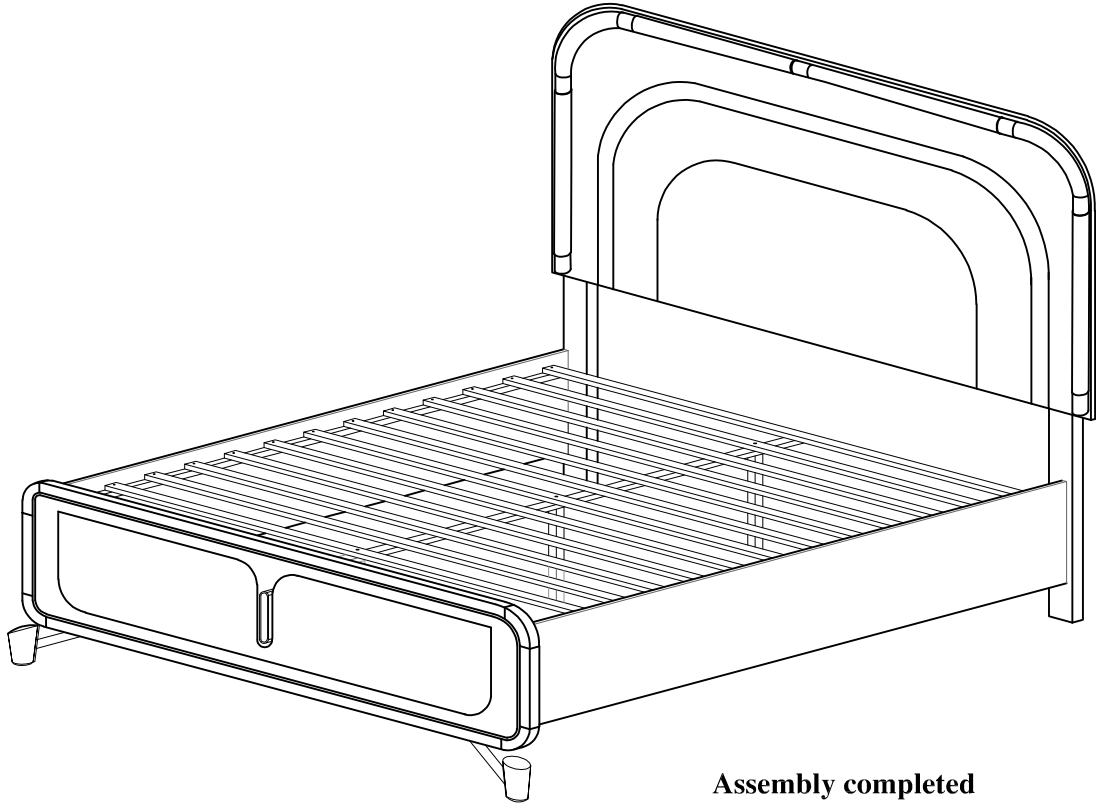

**Assembly completed**